

Package Contents



airFiber AF-5XHD



GPS Antenna Mount



External GPS Antenna



Metal Strap



Zip Ties (Qty. 2)



Universal Bracket



IP67 Upgrade Kit
(Vent and Gasket)



Gigabit PoE (24V, 1A) with
Mounting Bracket



Power Cord

Antenna Compatibility

The airFiber AF-5XHD radio is designed for use with the following airFiber X antenna models:

- AF-5G23-S45
- AF-5G30-S45
- AF-5G34-S45

The AF-5XHD can also operate with the following RocketDish™ antenna models:

- RD-5G30*
- RD-5G34*

** Requires Universal Bracket (included) or AF-5G-OMT-S45 Conversion Kit (not included).*

Installation Requirements

- Clear line of sight between airFiber radios
- Clear view of the sky for proper GPS operation
- Vertical mounting orientation
- Mounting point:
 - At least 1 m below the highest point on the structure
 - For tower installations, at least 3 m below the top of the tower
- Ground wires – min. 10 AWG (5 mm²) and max. length: 1 m. As a safety precaution, ground the airFiber radio to grounded masts, poles, towers, or grounding bars.



WARNING: Failure to properly ground your airFiber radio will void your warranty.

- (Recommended) 2 Outdoor Gigabit PoE surge protectors



Note: For guidelines about grounding and lightning protection, follow your local electrical regulatory codes.

- Outdoor, shielded Category 6 (or above) cabling and shielded RJ-45 connectors are required for all wired Ethernet connections.

Hardware Overview

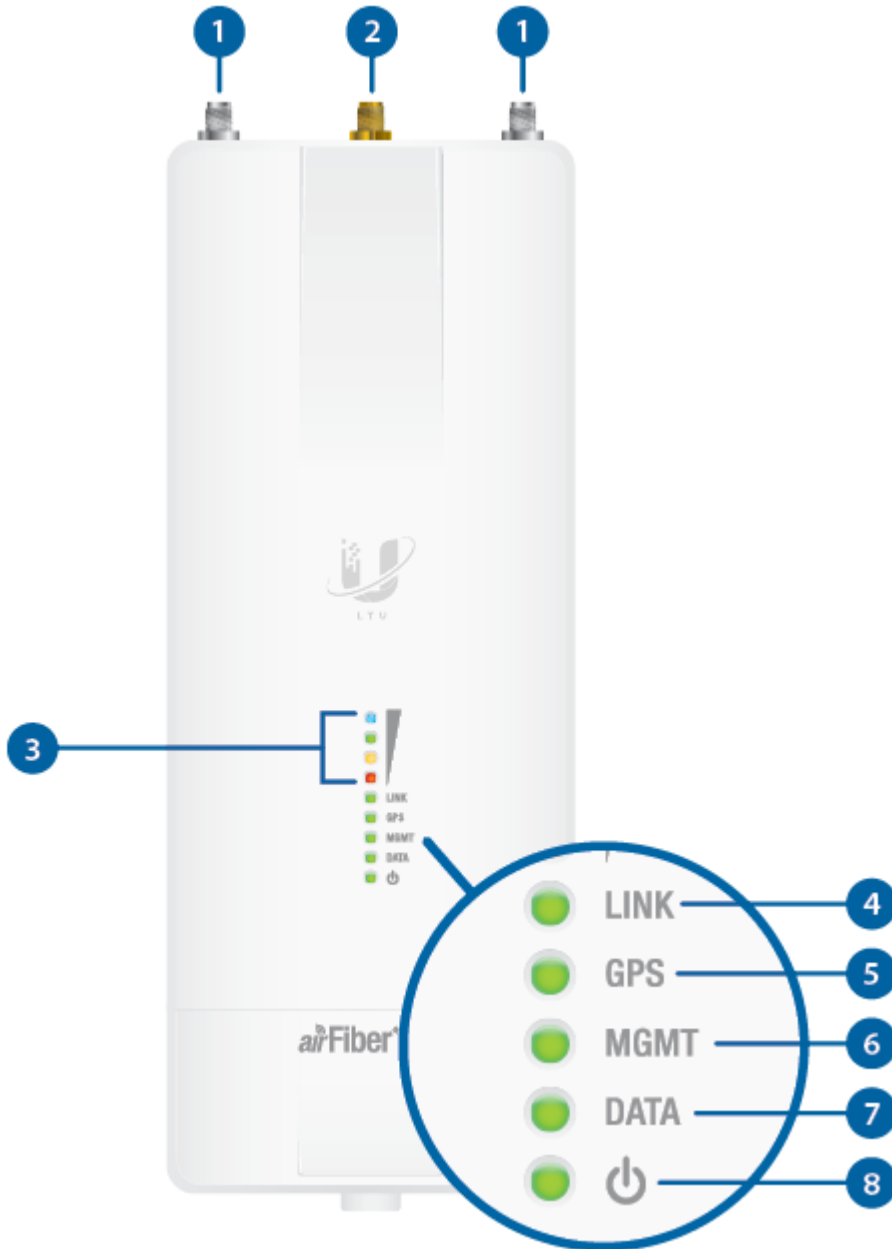

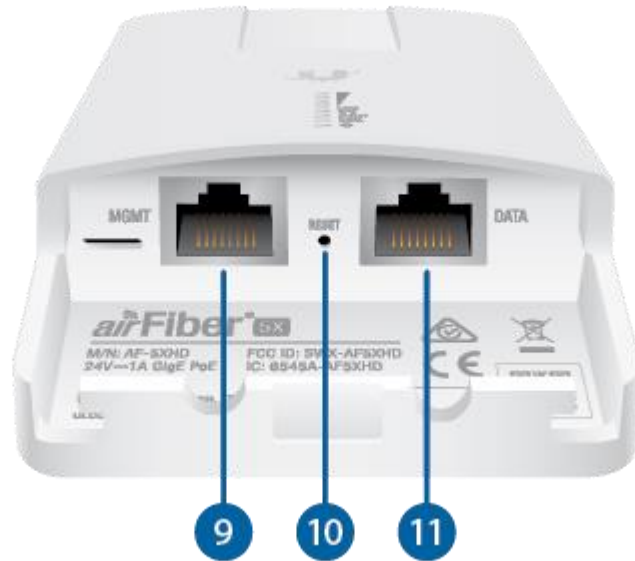

1

airFiber Antenna Connectors

Used to attach RF antenna cables (not included).

2

GPS Antenna Connector

Used to attach the GPS Antenna.

3

Signal LEDs



Signal 4 LED will light blue when on.



Signal 3 LED will light green when on.



Signal 2 LED will light yellow when on.



Signal 1 LED will light red when on.

Bootup to airOS When powering on, the Power, GPS, Link, and Signal 1-4 LEDs light on. Once the CPU code takes over, the GPS, Link, and Signal 1-3 LEDs turn off. The Signal 4 LED remains on to indicate the boot sequence is underway.

Initializing airFiber Software When the airFiber application begins to boot under airOS®, the Signal 4 LED goes from solidly on to a 2.5 Hz flash. This continues until the AF-5XHD is fully booted.

Signal Level Once fully booted, the Signal 1-4 LEDs act as a bar graph showing how close the AF-5XHD is to ideal aiming. This is auto-scaled based on the link range, the antenna gains, and the configured TX power of the remote AF-5XHD. Each Signal LED has three

possible states: On, Flashing, and Off. All Signal LEDs would be solidly on in an ideal link. If the link has a 1 dB loss, the Signal 4 LED will flash; a 2 dB loss and the Signal 4 LED will turn off. The full bar graph LED states are shown below.

dB loss						
0	-1	-2	-3	-4	-5	-6
-7	-8	-9	-10	-11	-12	-13

4
Link LED

Off	RF Off
	Syncing
	Beaconing
	Registering
On	Operational

5
GPS LED

Off	No GPS Synchronization
	Non-Operational (Weak Signal)
On	Operational (Strong Signal)

6
MGMT LED

Off	No Ethernet Link
-----	------------------

On	Ethernet Link Established
Random Flash	Ethernet Activity
7 Data LED	
Off	No Ethernet Link
On	Ethernet Link Established
Random Flash	Ethernet Activity
8 Power LED	
Off	No Power
On	Powered On
9 Management Port	
10/100/1000 Mbps, secured Ethernet port for configuration. In-Band Management is enabled by default in the airFiber Configuration Interface. When In-Band Management is disabled, the MGMT port is the only port that can monitor, configure, and/or update firmware. This port can also be used to provide redundant PoE power. Default IP address: 192.168.2.20	
10 Reset Button	
To reset to factory defaults, press and hold the Reset button for more than 10 seconds while the device is powered on.	
11 Data Port	
Gigabit PoE port for handling all user traffic and powering the device. Default IP address: 192.168.1.20	

Installation Overview

We recommend that you configure your paired AF-5XHD radios before site installation. The overview below summarizes the installation procedure, and the subsequent sections provide detailed installation information.

- Connect the airFiber PoE Adapter to the Data port, and connect your computer to the MGMT port.
- Configure the AF-5XHD.
- Recommended: Install the IP67 Upgrade Kit (included) to prevent intrusion by water, dust, and insects.
- Install a ground wire and mount the AF-5XHD on an airFiber X or RocketDish antenna.
- At the installation site, install the airFiber X or RocketDish antenna with the mounted AF-5XHD radio (see the antenna's Quick Start Guide for installation instructions).
- Secure the ground wire and mount the GPS antenna.
- Establish and optimize the RF link.

Connecting Power over Ethernet



1.

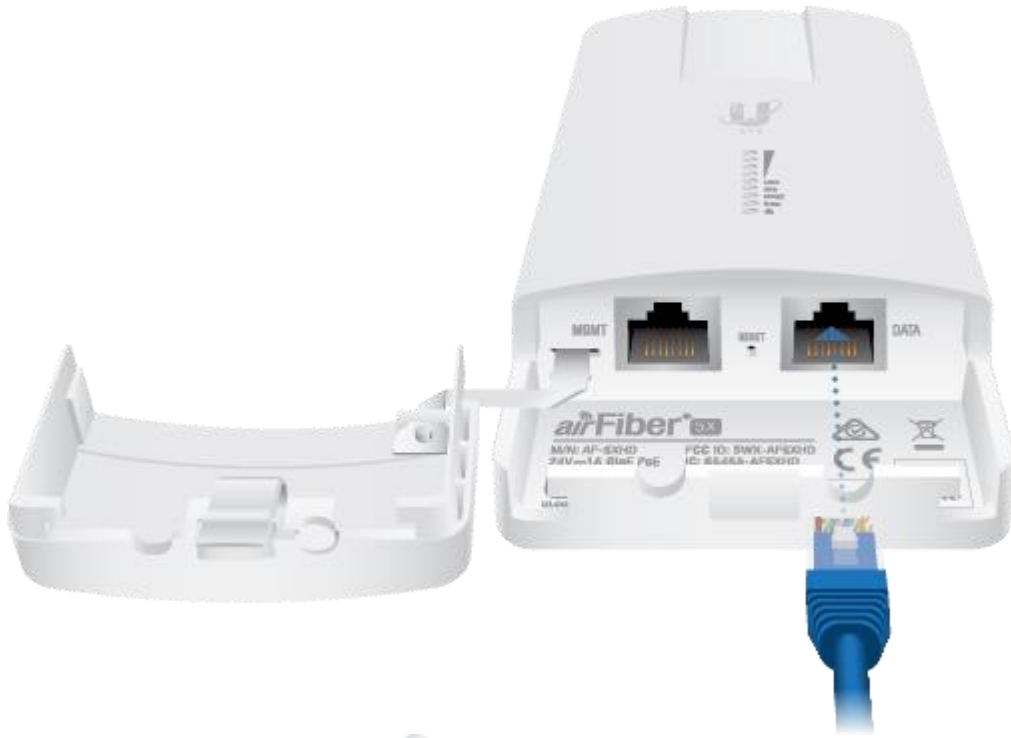

2.



3.



WARNING: Use only the included adapter, model POE-24V-5X-HD. Failure to do so can damage the unit and void the product warranty.

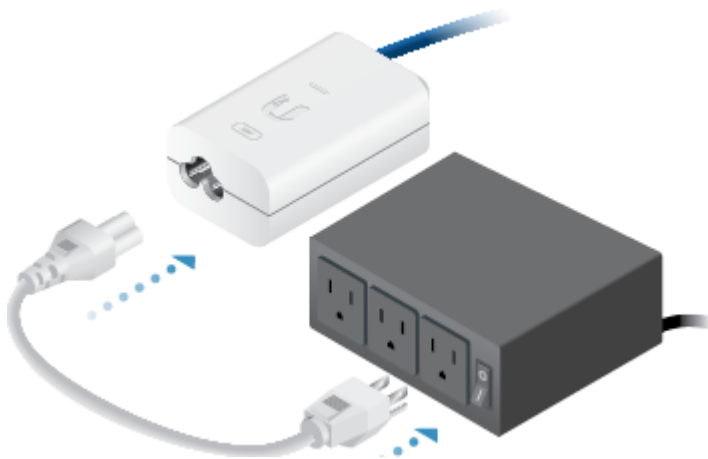

4.

airFiber Configuration

The instructions in this section explain how to access the airFiber Configuration Interface and configure the following settings:

- [Wireless Mode](#) Configure one AF-5XHD as the Master and the other as the Slave.
- [Frequency Setting](#) The operating Frequency must be the same on both the Master and the Slave.

There are two methods for configuration:

- Ubiquiti® Network Management System (preferred method)
- airFiber Configuration Interface (browser-based interface)

Configuration Using UNMS



1. Launch the UNMS app.
2. Optional: Enable Bluetooth on your mobile device.



Note: By default, Bluetooth is enabled on the AF-5XHD.

3. On the Connections screen, select the AF-5XHD.
4. Enter ubnt in the Username and Password fields. Select your Country and Language. You must agree to the Terms of Use to use the product.



Note: U.S. product versions are locked to the U.S. Country Code to ensure compliance with FCC regulations.

5. On the Summary screen, tap Configuration, and then tap Wireless.

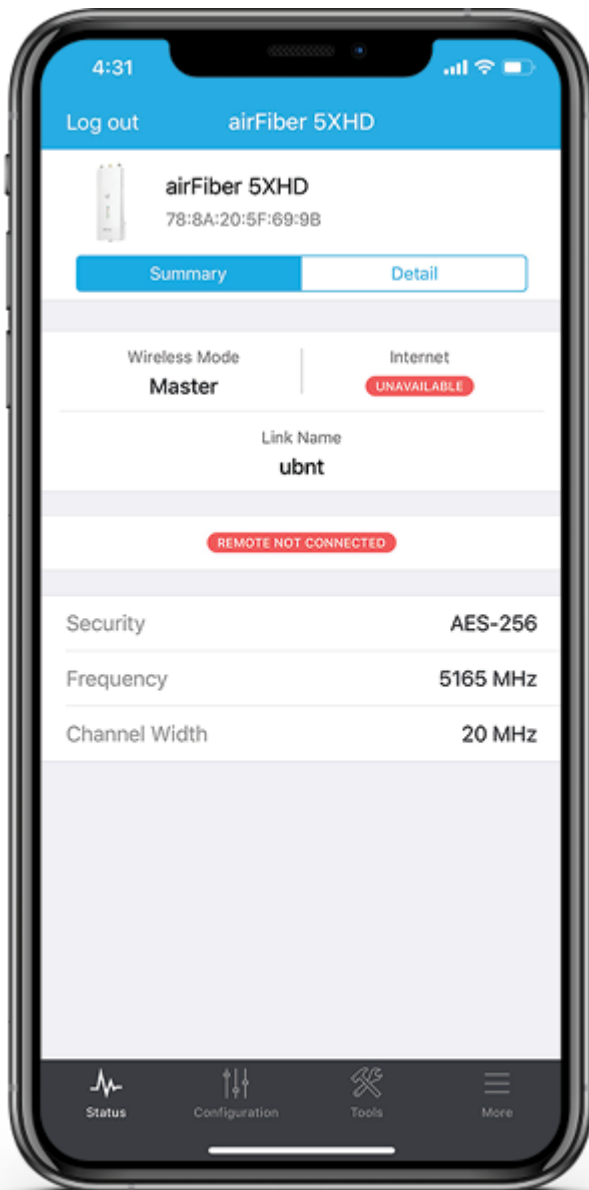

Note: UNMS screens shown here are from the iOS-based app. The Android-based app differs slightly in appearance and operation.

6. Configure these settings:
 - a. On one AF-5XHD, enable Master Mode; on the other AF-5XHD, keep the default setting (Off) for Master Mode.
 - b. Enter a name in the Link Name field. This should be the same on both the Master and the Slave.
 - c. Select your Country.



Note: U.S. product versions are locked to the U.S. Country Code to ensure compliance with FCC regulations.

d. If needed, change the Channel Bandwidth, Frequency, Output Power (EIRP), Antenna Gain, and Max TX Modulation settings. The Channel Bandwidth and Frequency should be the same on both the Master and the Slave.

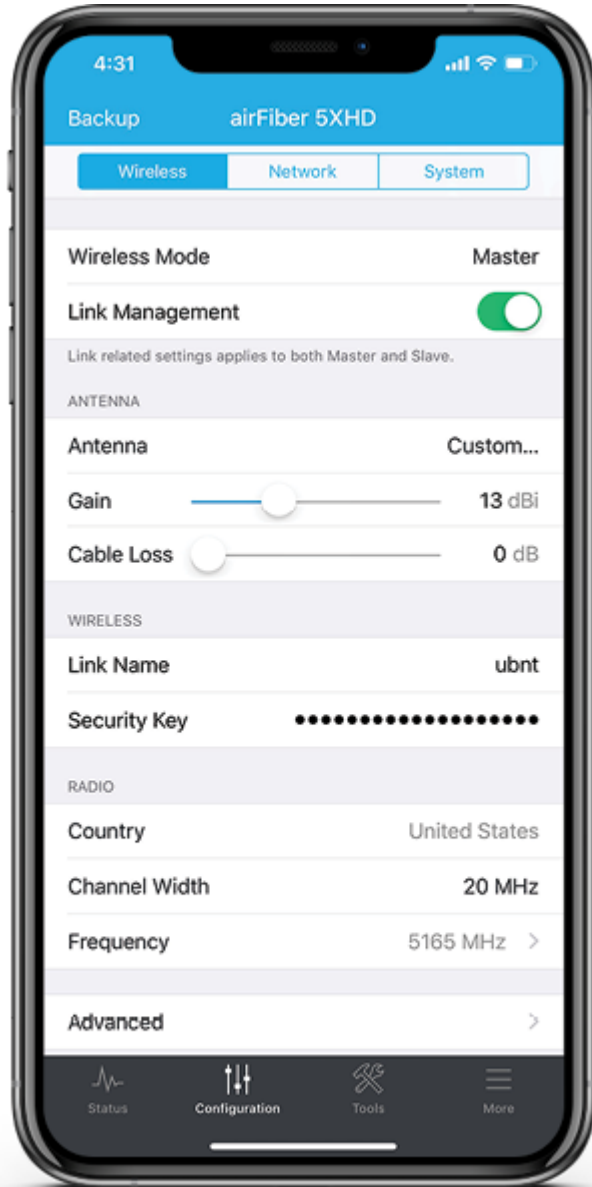

e. In the Security Key field, enter a combination of alphanumeric characters (0-9, A-Z, or a-z).



Note: The key is an alphanumeric password between 8 and 63 characters long.

7. Click Save Changes.
8. Configure each airFiber radio with a unique IP address for the Data port:
 - . Tap Configuration, and then tap Network.
 - a. For both the Data LAN Network and Management Network options:

- **DHCP** Have your router use DHCP reservation to assign a unique IP Address.
- **Static** Change the IP Address, Netmask, and other settings to make them compatible with your network.

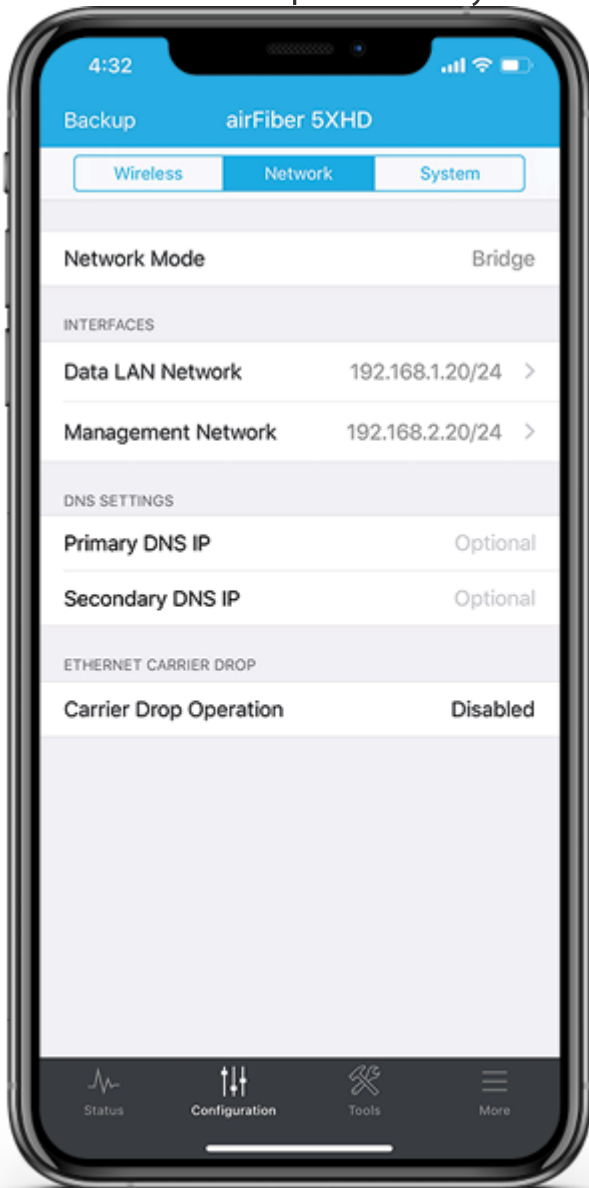

Configuration Using Browser-Based Interface

1. Optional (if the Data port is used for power only):

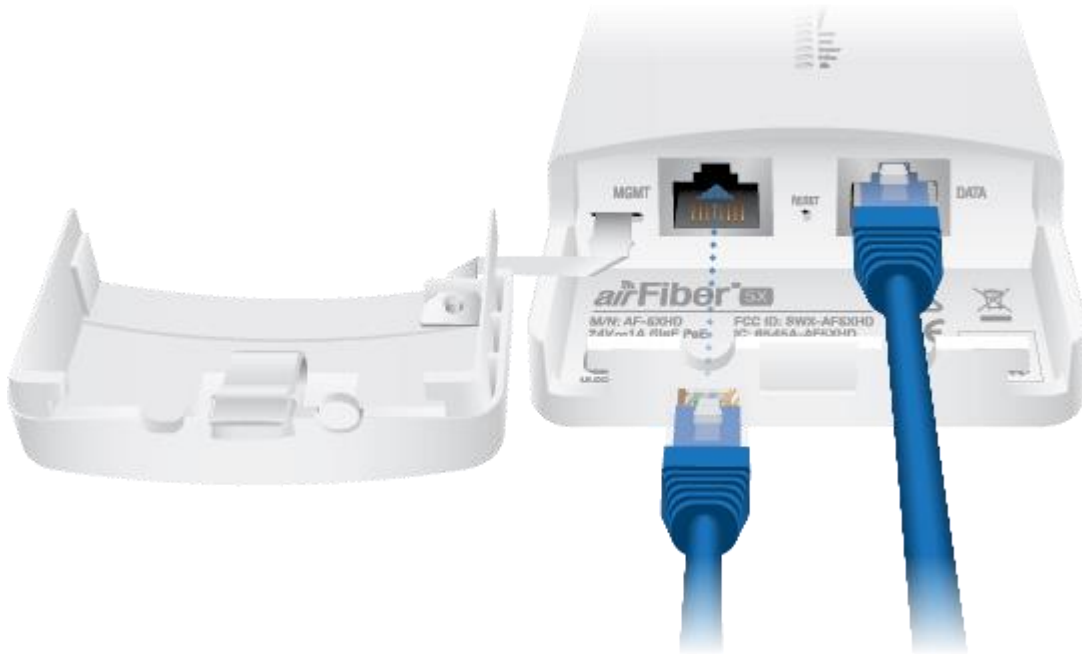

2. Configure the Ethernet adapter on your computer with a static IP address on the 192.168.2.x subnet.
3. Launch your web browser. In the address field, type the address of the port you are using to manage the device:
 - <http://192.168.2.20> (Management port)
 - <http://192.168.1.20> (Data port)Then press enter (PC) or return (Mac).

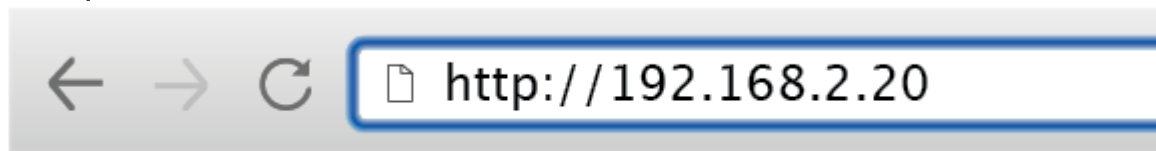

4. Enter ubnt in the Username and Password fields. Select your Country and Language. You must agree to the Terms of Use to use the product. Click Login.



Note: U.S. product versions are locked to the U.S. Country Code to ensure compliance with FCC regulations.

5. Click the  icon.
6. Configure the following settings:
 - . For one AF-5XHD, enable Master Mode. For the other AF-5XHD, disable Master Mode.
 - a. Enter a name in the Link Name field. This should be the same on both the Master and the Slave.
 - b. Select your Country.



Note: U.S. product versions are locked to the U.S. Country Code to ensure compliance with FCC regulations.

- c. If needed, change the Channel Bandwidth, Frequency, Output Power (EIRP), Antenna Gain, and Max TX Modulation settings. The Channel Bandwidth and Frequency should be the same on both the Master and the Slave.
- d. In the Security Key field, enter a combination of alphanumeric characters (0-9, A-Z, or a-z).



Note: The key is an alphanumeric password between 8 and 63 characters long.

7. Click Save Changes.
8. Configure each airFiber radio with a unique IP address for the Data port:
 - . Click the  icon.
 - a. For both the Data IP Address and Management IP Address options:
 - **DHCP** Have your router use DHCP reservation to assign a unique IP Address.
 - **Static** Change the IP Address, Netmask, and other settings to make them compatible with your network.
 - b. Click Save Changes.

Repeat the instructions in the airFiber Configuration section on the other AF-5XHD radio. For details on the airFiber Configuration Interface, refer to the airFiber AF-5XHD User Guide, available at: ui.com/download/airfiber

Upgrade for IP67 Compliance

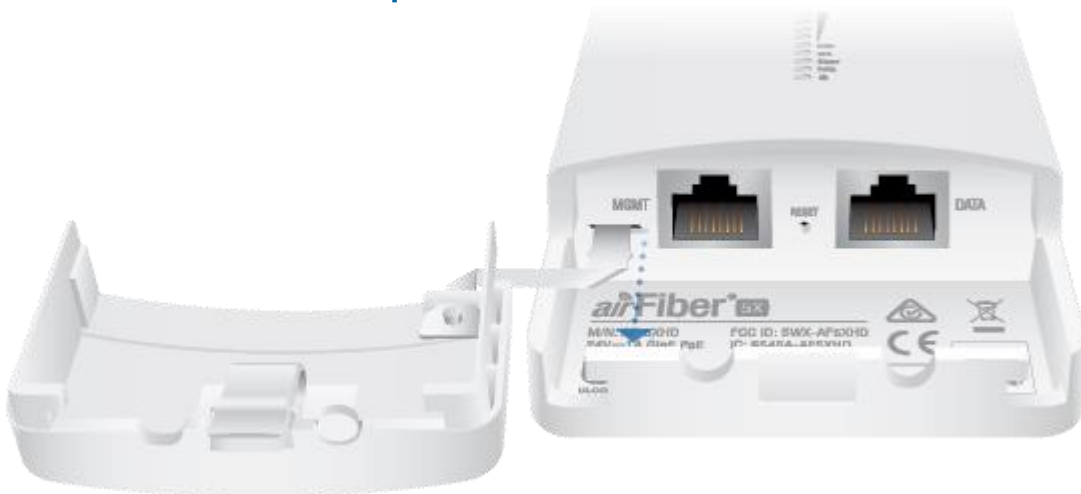

1.

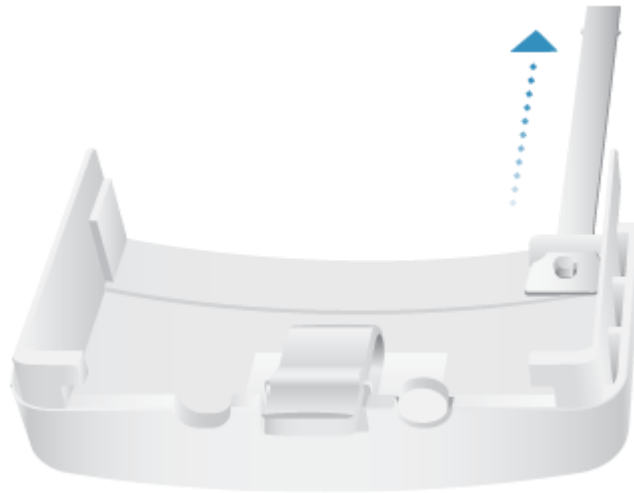

Note: Do not damage or remove the post on the Port Cover.

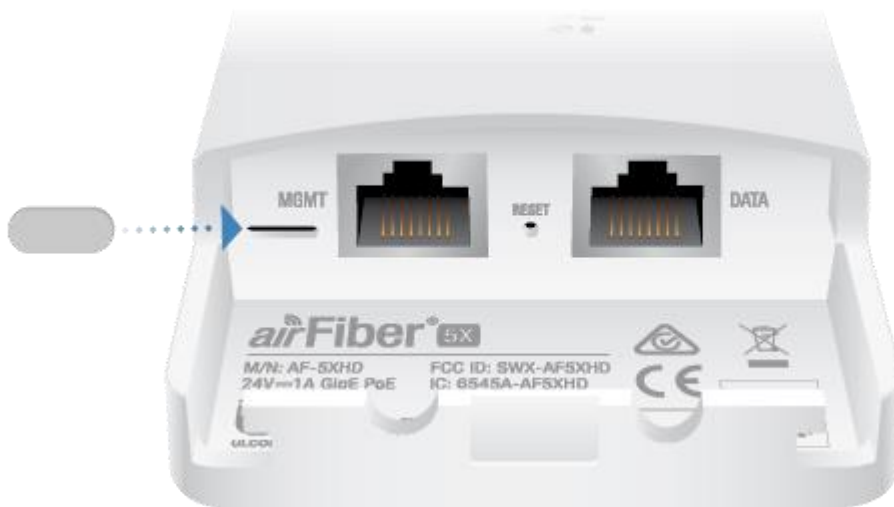

2.



3.

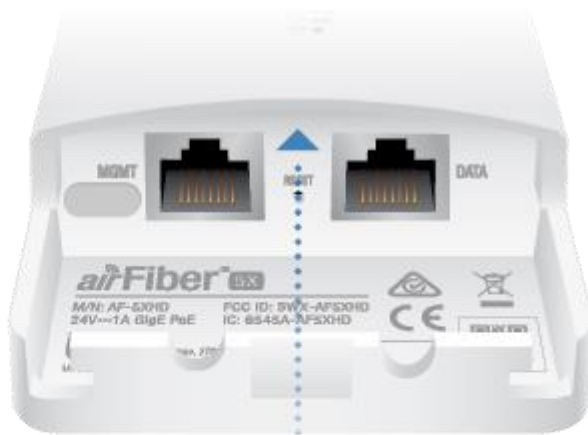

4.

Hardware Installation

Installing the Ground Wire

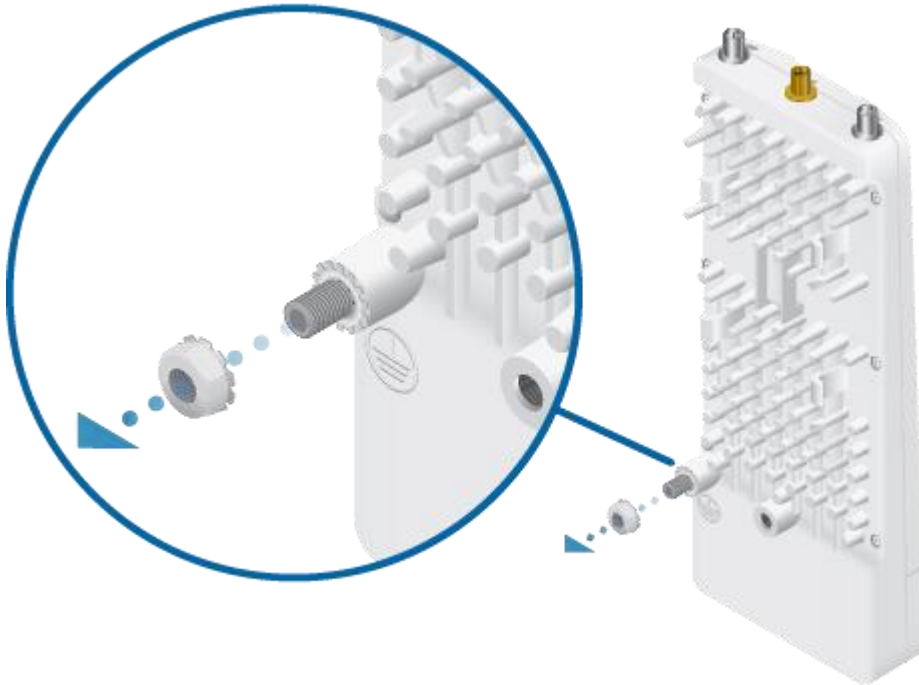

1.



2.

3. At the installation site, secure the other end of the ground wire to a grounded mast, pole, tower, or grounding bar.



WARNING: Failure to properly ground your airFiber radio will void your warranty.



Note: The ground wire should be as short as possible and no longer than one meter in length.

Mount to an airFiber X Antenna



Note: To mount the AF-5XHD to a RocketDish using the included Universal Bracket, see the [Mount to a RocketDish Antenna](#) section.

The airFiber X antenna AF-5G23-S45 is shown in this section:





2.



3.



4.

Mount to a RocketDish Antenna



Note: If you are mounting the AF-5XHD on a RocketDish equipped with the AF-5G-OMT-S45 Conversion Kit, the Universal Bracket is not needed. Refer instead to the [Mount to an airFiber X Antenna](#) section for instructions.

The RocketDish RD-5G30 antenna is shown in this section:

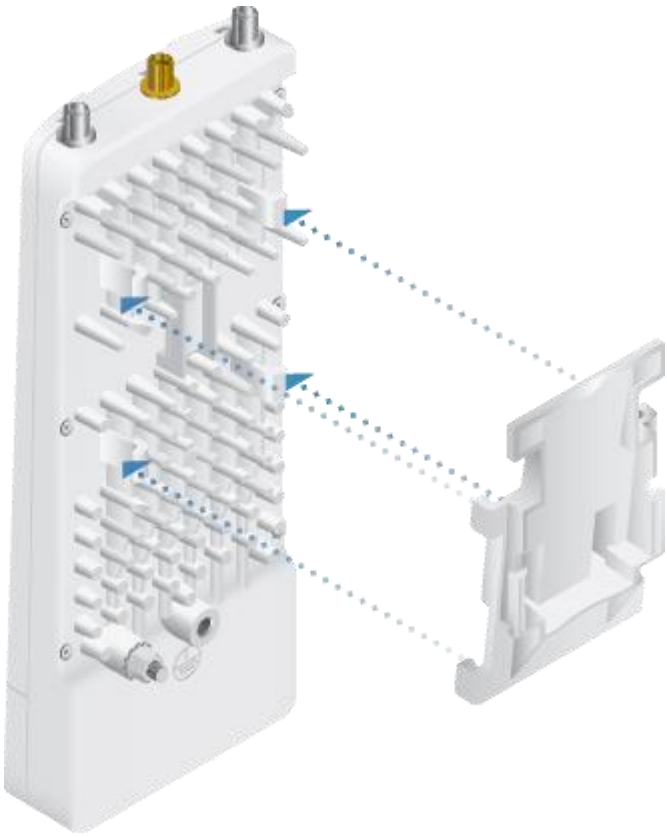

1.



2.

Mount the External GPS Antenna

Locate a mounting point that has a clear view to the sky, and is above and as far away as possible from the AF-5XHD.

1.

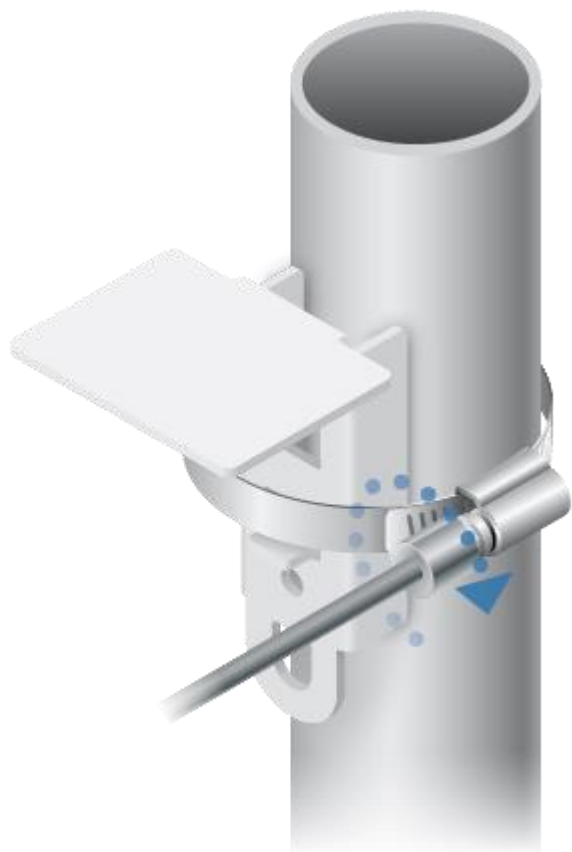

OR

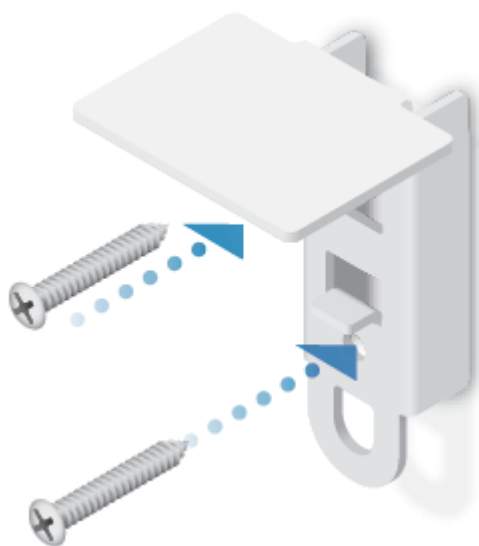



2.



3.

Connecting Power over Ethernet



1.
2.



OR



Note: If the IP67 Upgrade Kit is installed, first apply dielectric grease to the cable connector and port.

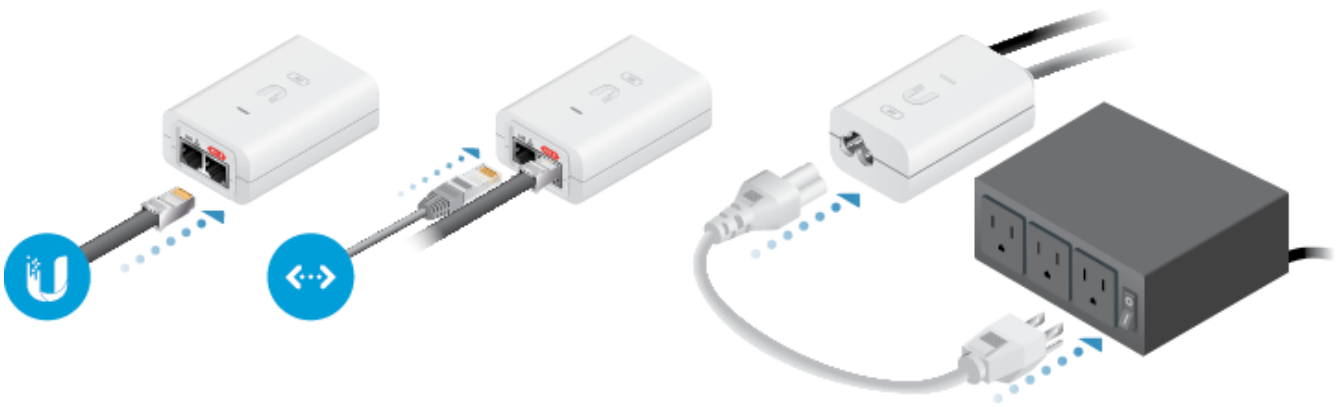

3.



WARNING: Use only the included adapter, model POE-24V-5X-HD. Failure to do so can damage the unit and void the product warranty.

Optional

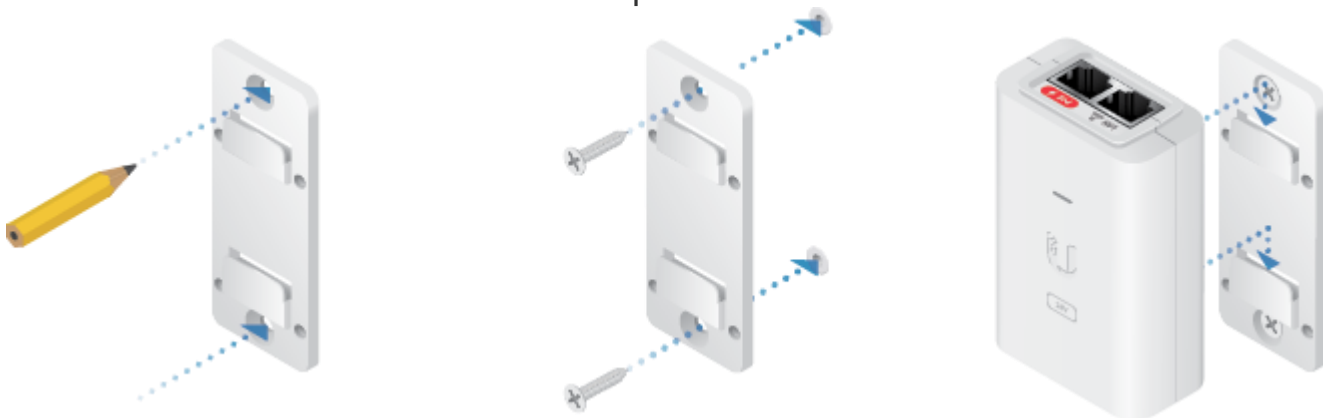

Surge Protection

For added protection, install two surge suppressors, such as the Ubiquiti Ethernet Surge Protector, model ETH-SP, at the end of each link. Install the first surge protector within one meter of the airFiber Data port, and install the second surge protector at the ingress point of the location housing the wired network equipment.

AF-5XHD

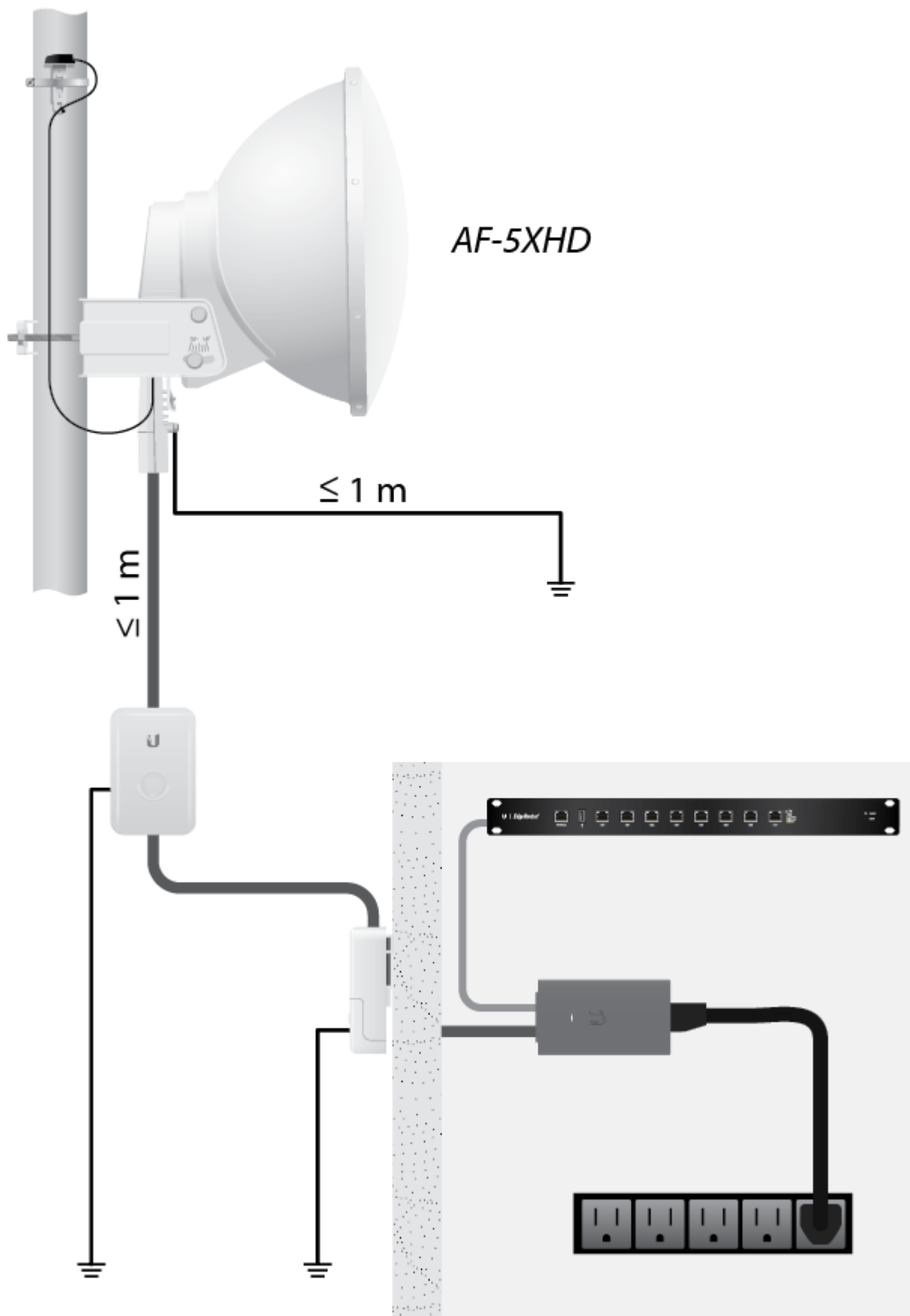

Alignment

Tips

- To accurately align the airFiber radios for best performance, you **MUST** align only one end of the link at a time.
- You may need to use additional hardware to compensate for issues such as the improper orientation of a mounting pole or significant elevation differences between airFiber radios.

Establishing a Link

Adjust the positions of the Master and the Slave to establish a link. The following section features the airFiber X antenna, AF-5G23-S45:



Note: The Master must be aimed first at the Slave because the Slave does not transmit any RF signal until it detects transmissions from the Master.

1. **Master** Visually aim the Master at the Slave. To adjust the Master's position, adjust the azimuth and the elevation.

Adjust the azimuth:

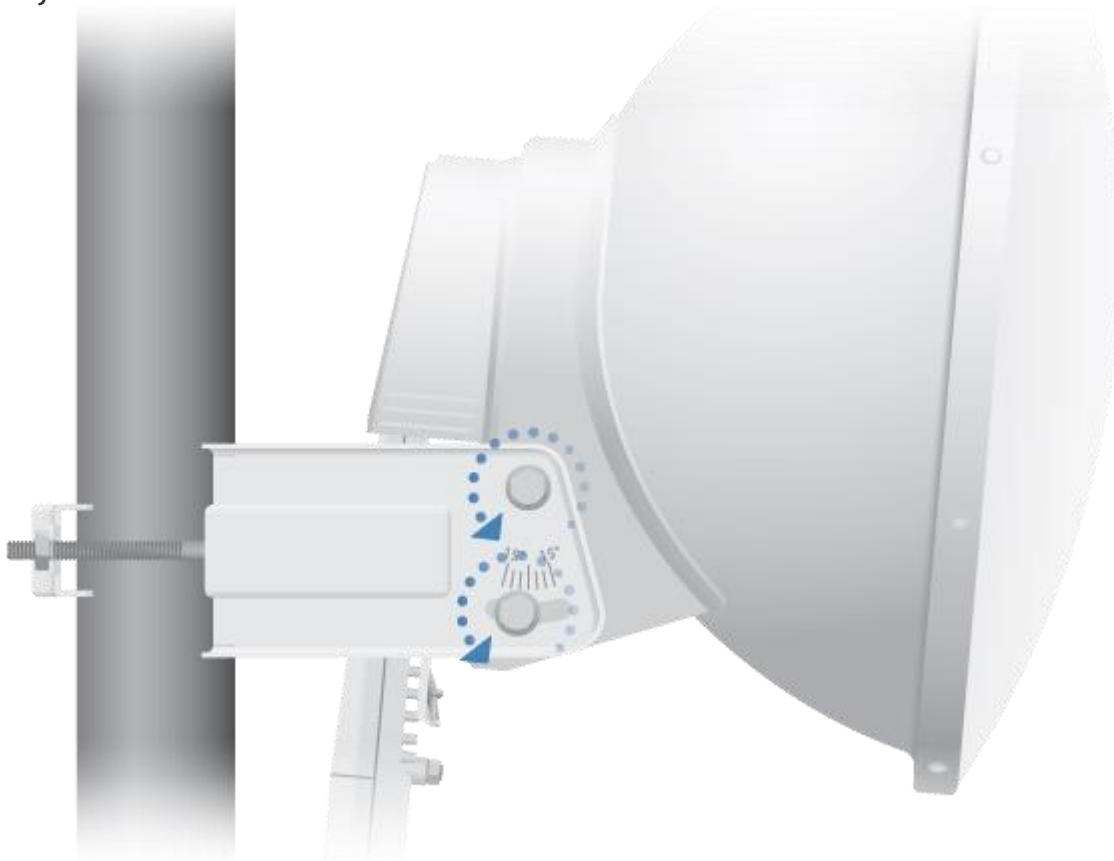



2.

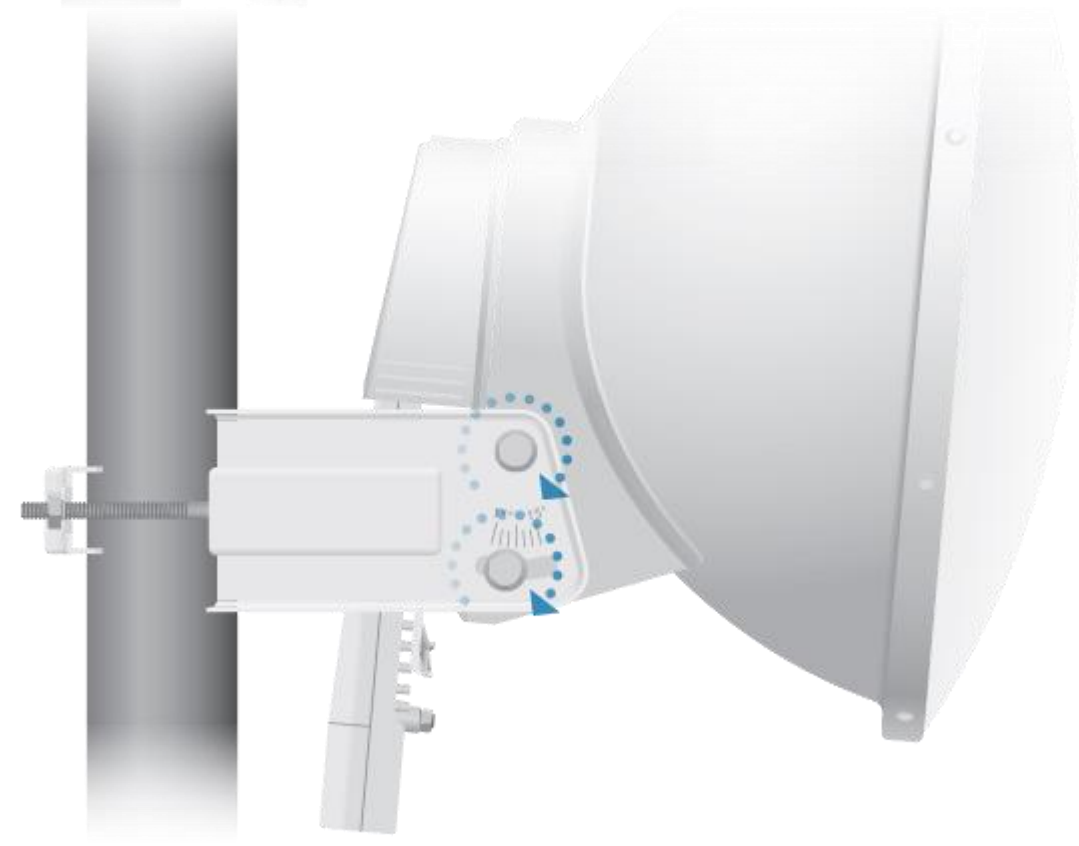

3.



Note: Do NOT make simultaneous adjustments on the Master and Slave.

4. **Slave** Visually aim the Slave at the Master. To adjust the Slave's position, adjust the azimuth and elevation as described in step 1.
5. Check to see if a link is established. Ensure that the Link LED is solidly lit green and the Signal LEDs of the Slave are displaying signal levels.



6. **Slave** Aim the Slave at the Master to achieve the strongest signal level on the Master.



Note: Refer to the Signal LEDs section for details on the signal values.



Note: Maximum signal strength can best be achieved by iteratively sweeping through both azimuth and elevation.

7. **Master** Aim the Master at the Slave to achieve the strongest signal level on the Slave.
8. Repeat steps 4 and 5 until you achieve an optimal link, with all four Signal LEDs solidly lit. This ensures the best possible data rate between the airFiber radios.
9. Lock the alignment on both airFiber antennas by tightening all the nuts and bolts.
10. Observe the Signal LEDs of each airFiber radio to ensure that the values remain constant while tightening the nuts and bolts. If any LED value changes during the locking process, loosen the nuts and bolts, finalize the alignment of each airFiber antenna again, and retighten the nuts and bolts.

Installer Compliance Responsibility

Devices must be professionally installed and it is the professional installer's responsibility to make sure the device is operated within local country regulatory requirements.

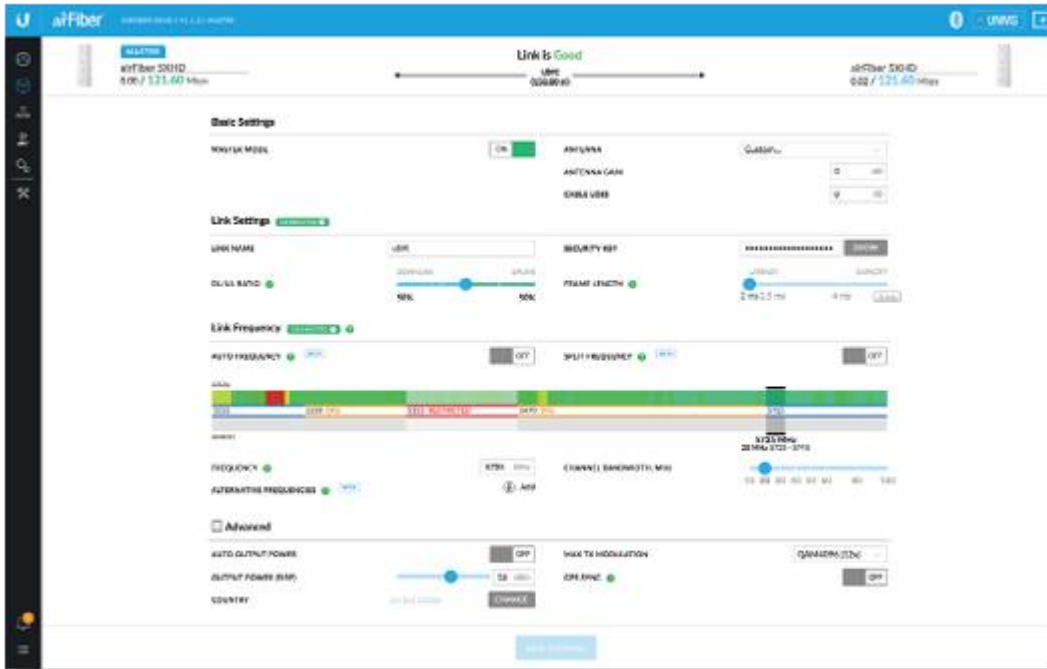

Antenna

Select your antenna from the list. If Auto Output Power is enabled, transmit output power is automatically adjusted to comply with the regulations of the applicable country. For a Custom antenna, Antenna Gain is entered manually. Note the requirements and antenna types listed below.

Cable Loss (When applicable)

Enter the cable loss in dB. Output power is adjusted to compensate for loss between the radio and the antenna.

Certified Antenna Types

This radio transmitter FCC ID: SWX-AF5XHD / IC: 6545A-AF5XHD has been approved by FCC / ISED Canada to operate with the antenna types listed below with the maximum permissible gain for each antenna type indicated. Antenna types not included in this list or having a gain greater than the maximum gain indicated for that type, are strictly prohibited for use with this device.

Antenna	Frequency	Gain
Dish	5 GHz	34 dBi

Specifications

AF-5XHD	
Dimensions	224 x 82 x 48 mm (8.82 x 3.23 x 1.89")
Weight	0.35 kg (12.3 oz)
RF Connectors	(2) RP-SMA Weatherproof (CH0, CH1)

AF-5XHD	
	(1) SMA Weatherproof (GPS)
GPS Antenna	External, Magnetic Base
Power Supply	24V, 1A PoE Gigabit Adapter (Included)
Power Method	Passive Power over Ethernet Pins 1, 2; 4, 5+ and Pins 7, 8; 3, 6-
Supported Voltage Range	+18 to +54VDC ₁
Max. Power Consumption	6-12W ₂
Networking Interface	
Data Port	(1) 10/100/1000 Ethernet Port
Management Port	(1) 10/100/1000 Ethernet Port Bluetooth v4.0
Mounting	airFiber X Mount (Rocket Mount Compatible) GPS Pole Mount (Included)
Operating Temperature	-40 to 55° C (-40 to 131° F)
Weatherproofing	IP67 ₃
Certifications	CE, FCC, IC

₁ Full range depends on Ethernet cable length.

₂ Varies with firmware load and operational mode.

₃ After installation of IP67 Upgrade Kit (included).

System	
Maximum Throughput	1.34 Gbps _{1, 2}
Encryption	256-bit AES
OS	airOS LTU
Wireless Modes	Master/Slave

₁ May vary depending on environmental conditions.

₂ Assuming 4096QAM (requires firmware version 1.1.2 or above).

Radio	
Max. Conducted TX Power	29 dBm*
Frequency Accuracy	< 2 ppm

Radio		
Channel Bandwidth	10/20/30/40/50/60/80/100 MHz Selectable Programmable Uplink and Downlink Duty Cycles	
Operating Frequency (MHz)		
Worldwide	4800 - 6200*	
US/CA	U-NII-1	5150 - 5250
	U-NII-2A	5250 - 5350
	U-NII-2C	5470 - 5725
	U-NII-3	5725 - 5850

* Depends on regulatory region.

Bluetooth LE Management Radio (MHz)	
Worldwide	2400 - 2483.5

Safety Notices

1. Read, follow, and keep these instructions.
2. Heed all warnings.
3. Only use attachments/accessories specified by the manufacturer.



WARNING: Do not use this product in location that can be submerged by water.



WARNING: Avoid using this product during an electrical storm. There may be a remote risk of electric shock from lightning.

Electrical Safety Information

1. Compliance is required with respect to voltage, frequency, and current requirements indicated on the manufacturer's label. Connection to a different power source than those specified may result in improper operation, damage to the equipment or pose a fire hazard if the limitations are not followed.
2. There are no operator serviceable parts inside this equipment. Service should be provided only by a qualified service technician.
3. This equipment is provided with a detachable power cord which has an integral safety ground wire intended for connection to a grounded safety outlet.
 - a. Do not substitute the power cord with one that is not the provided approved type. Never use an adapter plug to connect to a 2-wire outlet as this will defeat the continuity of the grounding wire.
 - b. The equipment requires the use of the ground wire as a part of the safety certification, modification or misuse can provide a shock hazard that can result in serious injury or death.
 - c. Contact a qualified electrician or the manufacturer if there are questions about the installation prior to connecting the equipment.

- d. Protective earthing is provided by Listed AC adapter. Building installation shall provide appropriate short-circuit backup protection.
- e. Protective bonding must be installed in accordance with local national wiring rules and regulations.

Limited Warranty

ui.com/support/warranty

The limited warranty requires the use of arbitration to resolve disputes on an individual basis, and, where applicable, specify arbitration instead of jury trials or class actions.

Compliance

FCC / CAN ICES-3(B)/NMB-3(B)

Changes or modifications not expressly approved by the party responsible for compliance could void the user's authority to operate the equipment.

This device complies with Part 15 of the FCC Rules and ISSED Canada licence-exempt RSS standard(s).

Operation is subject to the following two conditions.

1. This device may not cause harmful interference, and
2. This device must accept any interference received, including interference that may cause undesired operation.

Le présent appareil est conforme aux CNR d'ISSED Canada applicables aux appareils radio exempts de licence. L'exploitation est autorisée aux deux conditions suivantes :

1. l'appareil ne doit pas produire de brouillage;
2. l'appareil doit accepter tout brouillage radioélectrique subi, même si le brouillage est susceptible d'en compromettre le fonctionnement.

This equipment has been tested and found to comply with the limits for a Class B digital device. These limits are designed to provide reasonable protection against harmful interference in a residential installation. This equipment generates, uses, and can radiate radio frequency energy and, if not installed and used in accordance with the instructions, may cause harmful interference to radio communications. However, there is no guarantee that interference will not occur in a particular installation. If this equipment does cause harmful interference to radio or television reception, which can be determined by turning the equipment off and on, the user is encouraged to try to correct the interference by one or more of the following measures:

- Reorient or relocate the receiving antenna.
- Increase the separation between the equipment and receiver.
- Connect the equipment into an outlet on a circuit different from that to which the receiver is connected.
- Consult the dealer or an experienced radio/TV technician for help.

IMPORTANT NOTE:

Radiation Exposure Statement:

- This equipment complies with radiation exposure limits set forth for an uncontrolled environment.
- This equipment should be installed and operated with minimum distance 108 cm between the radiator and your body.
- This transmitter must not be co-located or operating in conjunction with any other antenna or transmitter.

AVIS IMPORTANT :

Déclaration sur l'exposition aux rayonnements :

- Cet équipement est conforme aux limites prévues pour l'exposition aux rayonnements dans un environnement non contrôlé.
- Lors de l'installation et de la mise en fonctionnement de l'équipement, assurez-vous qu'il y ait une distance minimale de 108 cm entre l'élément rayonnant et vous.
- Cet émetteur ne doit être installé à proximité d'aucune autre antenne ni d'aucun autre émetteur, et ne doit être utilisé conjointement à aucun autre de ces appareils.

Australia and New Zealand



Warning: This equipment is compliant with Class A of CISPR 32. In a residential environment this equipment may cause radio interference.

Brazil



Nota: Este equipamento não tem direito à proteção contra interferência prejudicial e não pode causar interferência em sistemas devidamente autorizados.

CE Marking

CE marking on this product represents the product is in compliance with all directives that are applicable to it.



Country List



AT	BE	BG	CY	CZ	DE	DK	EE	EL	ES	FI	FR	HR	HU
IE	IT	LV	LT	LU	MT	NL	PL	PT	RO	SE	SI	SK	UK

BFWA (Broadband Fixed Wireless Access) members noted in blue



Note: This device meets Max. TX power limit per ETSI regulations.

The following apply to products that operate in the 5 GHz frequency range:



Note: This device is restricted to indoor use only when operating in the 5150 - 5350 MHz frequency range within all member states.



Note: All countries listed may operate at 30 dBm. BFWA member states may operate at 36 dBm.



Note: Operation in the 5.8 GHz frequency band is prohibited in BFWA member states. Other countries listed may use the 5.8 GHz frequency band.

WEEE Compliance Statement

Declaration of Conformity

Online Resources



© 2020 Ubiquiti Inc. All rights reserved.